

FANEC - Series Eco-Watt Powerful Inline Duct Fan

Features

- High performance: small fan body, unique design fan blade, strong airflow, big air pressure.
- High efficiency and energy saving: use a DC variable frequency motor (permanent magnet synchronous motor) for lower energy consumption.
- Meet EU ERP2018 energy efficiency standards.
- Free speed control: 0-10V voltage speed control and PWM signal speed control.
- Stable performance: set with slow starting, no influence during voltage fluctuation.
- Double NMB ball bearings, long working life - over 50.000 hours.
- Protection class: IP44
- Operating temperature range: -20°C ~60°C

Performance Parameter

Model	Voltage	Current (Amps)	Power (W)	Speed (RPM)	Airflow		Air Pressure (Pa)	Net Weight (kgs)
					(m ³ /h)	(m ³ /s)		
FANEC-160	100~240	0.70 MAX 1.40	77	4300	798	221.7	542	2.0

Dimensions

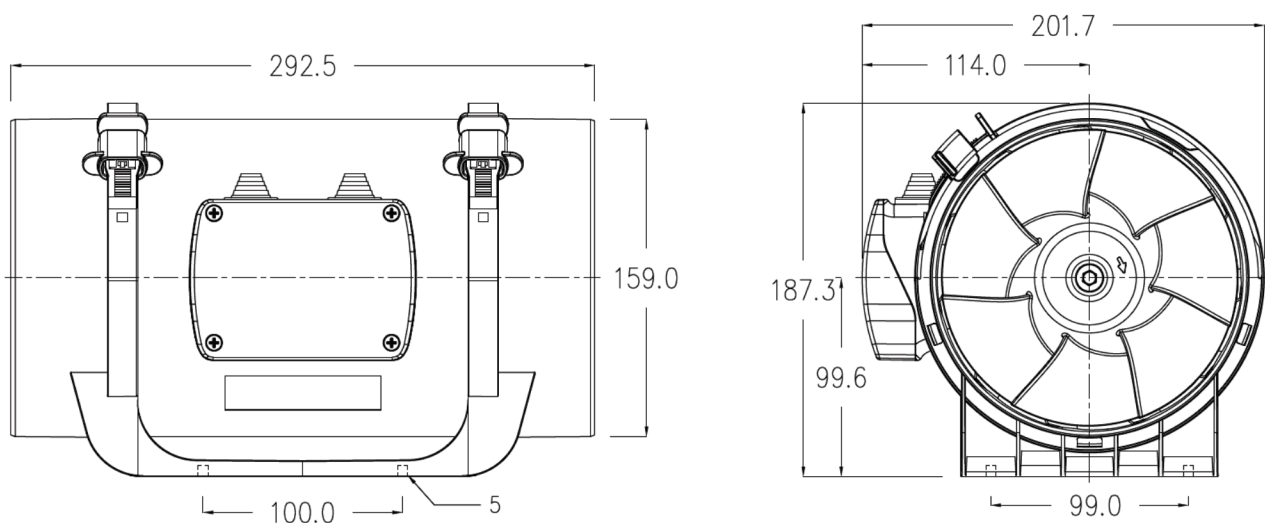

FANEC - Series Eco-Watt Powerful Inline Duct Fan

Performance Curves

